

Sound LED Bargraph

A. Awadhi

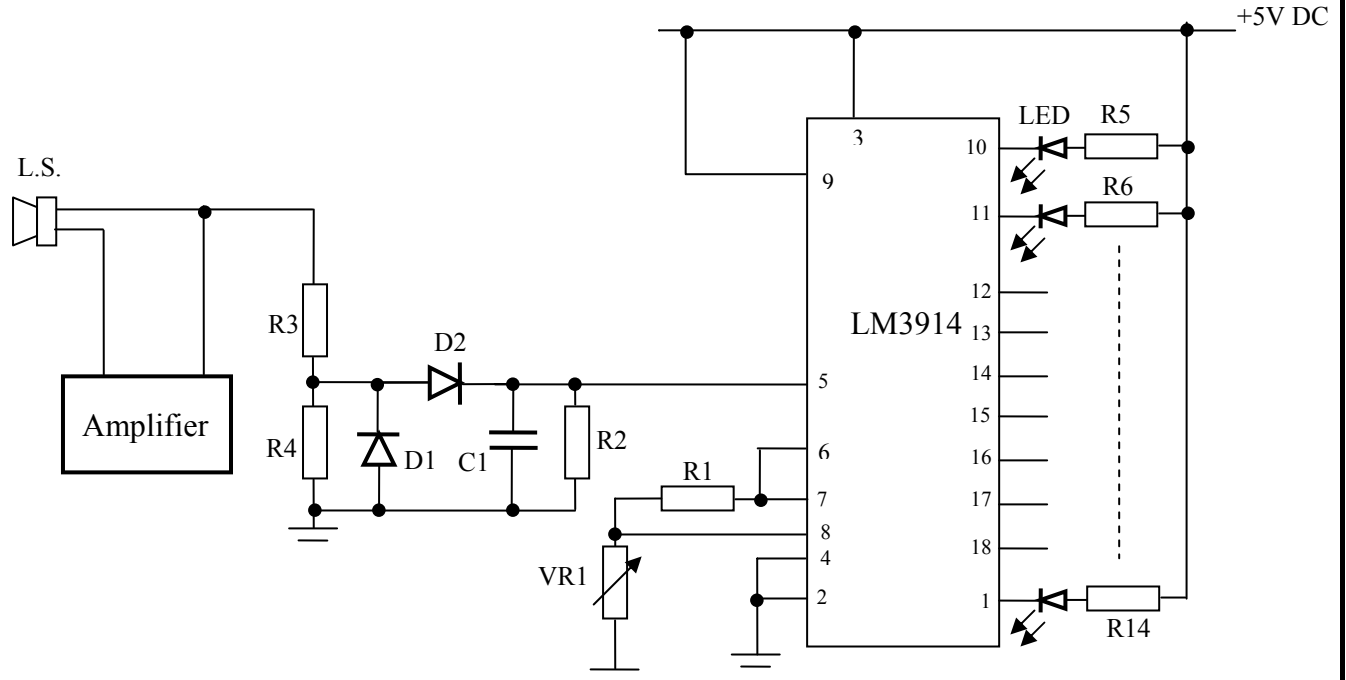

Circuit components:

Component	Value	Remarks
R1	390 Ω	
R2	470K Ω	
R3		Refer to table (2)
R4	10K Ω	
R5-R14	300 Ω	
VR1	1.5K Ω	
D1-D2	IN4001	
C1	0.22 μ F	

Table (1)

Circuit description

This circuit is used to measure sound level of an amplifier using IC LM3914. This IC can convert the analog input voltage applied to pin no. 5 to tin outputs on pins 1 & 10 through 18. As the analog input voltage increases the number of LED's lit will increase.

R3 & R4 They perform matching circuit between the amplifier output impedance and input of our circuit, where the value of R3 depends on impedance of the amplifier as shown in table (2). Note that without considering table (2) for value of R3 may cause the amplifier to damage.

LS Impedance	R3 Value
4Ω	10KΩ
8Ω	18KΩ
16Ω	30KΩ

Table (2)

The unstable audio signal will be rectified and smoothed by the components D1, D2, C1 & R2. R1 & VR1 they used to control the sensitivity of the circuit, you can control the number of LED's lit at specific sound level.

The IC LM3914 Can be used for application of measuring of temperature. However, in this case a temperature sensor circuit will be connected to the input of the IC instead of impedance matching and rectification circuits.

For more informations about LM3914 IC and its application please refer to its data sheet which can be found in the internet.